

# ProntoFLOW Control Series

## Programmable Multi-Fan Controller

### Features

- Accepts up to nine fans
- Synchronizes rotational speeds of 4-wire fans to eliminate "beat" noise and vibration
- Monitors speed of 3-wire fans
- Simultaneously controls up to two types of fans
- I2C and RS232 communication interfaces
- Field configurable through serial interface
- Programmable alarm thresholds & fan curve
- Open collector alarm output
- One onboard/ two external temperature sensors
- Non-volatile memory to store configuration
- Power & Alarm LEDs with external connections
- Software selectable 3.3/5V logic operation
- Isolated Fan and Logic power domains
- Single/Dual power input
- Inrush current limiter for "hot swap"
- Fan failure detection and prediction

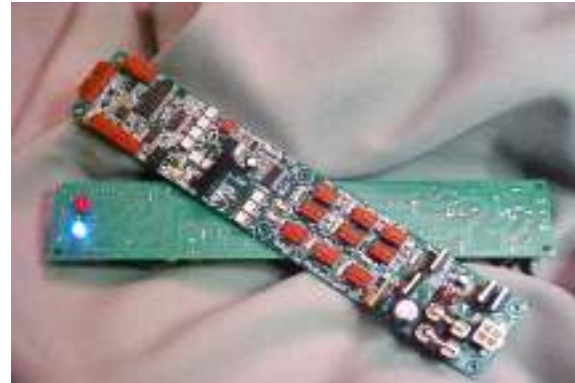

### Description

The ProntoFLOW Control series is a line of off-the-shelf programmable controllers from DegreeC for thermal management and fan speed control of DC fans. Years of experience in thermal management and fan controller development is distilled into this product. These intelligent controllers are designed for use in 1U or larger fan tray applications. This series has multiple controller boards that are adaptable for a variety of uses.

The PCD1 controller board can be used for a broad range of applications and can be configured rapidly by user through *ProntoFLOW Configure* software running on Windows PC. PCD1 can control up to nine fans and measure temperature from three sensors. The input power is fed to the fans after polarity, fuse protection and filter. Each fan power is individually fused for higher fail-safe protection.

The microcontroller on board controls or monitors fan speeds, communicates with host through serial interfaces, measures temperatures, detects filter blockage and reports alarms. The control curve and alarm thresholds are programmable through serial link and stored in non-volatile memory. Nine fans of two different types may be used simultaneously. This board is designed to work with *ProntoFLOW Power* regulation boards for wide voltage applications.

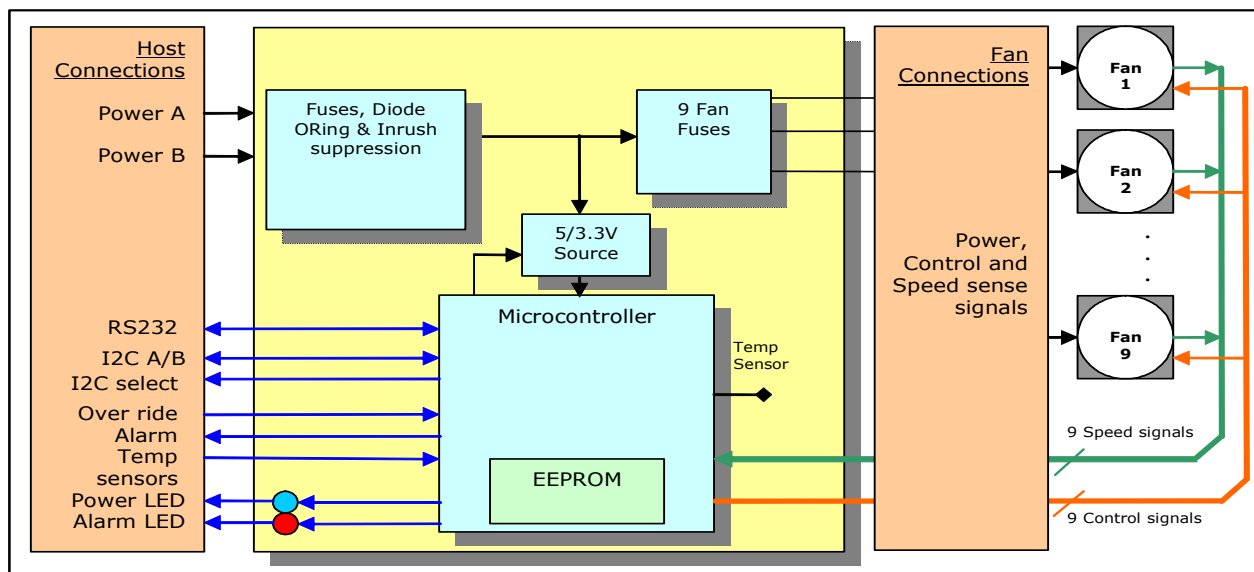

## Electrical Specifications

	Min	Nom	Max	Units
Input Voltage(=Fan voltage)	18	48	60 (Max Fan Volt)	Volts DC
Input Current		3	5 <sup>2</sup>	Amps DC
Inrush Current		1.5	2	Amps DC
Fan Current <sup>1</sup>		0.8	1	Amps DC
Isolation			1500	VDC

**Notes:**

- 1 Current to each fan, total fan current limited to Maximum Input Current.
- 2 Requires airflow of 200 LFM

## Connections

J1: Power Connector. Molex: 39-28-9048		J13: PWM switch. Molex: 22-11-2022		J2-10: Fan Connectors. Molex: 22-11-2042		J11: Logic Signals Molex: 22-11-2122		J16: Sensor/LED Signals Molex: 22-11-2082					
Pin #	Signal	Pin#	Signal	Pin #	Signal	Pin #	Signal	Pin#	Signal	Pin #	Signal	Pin #	Signal
1	-48_A (Power)	1	PWM+	1	Return-	1	EXT +5V	7	SCL-2 (I2C)	1	Thermistor 1 +	5	ALARM LED +
2	-48_A RTN	2	PWM-	2	Vfan+	2	D-Gnd	8	SDA-2 (I2C)	2	Thermistor 1 -	6	ALARM LED -
3	-48_B (Power)			3	Tachometer	3	RXD (RS232)	9	Override (TTL)	3	Thermistor 2 +	7	POWER LED +
4	-48_B RTN			4	Control	4	TXD (RS232)	10	I2C Select	4	Thermistor 2 -	8	POWER LED -
						5	SCL-1 (I2C)	11	Alarm -				
						6	SDA-1 (I2C)	12	Alarm+				

## Mechanical Specifications

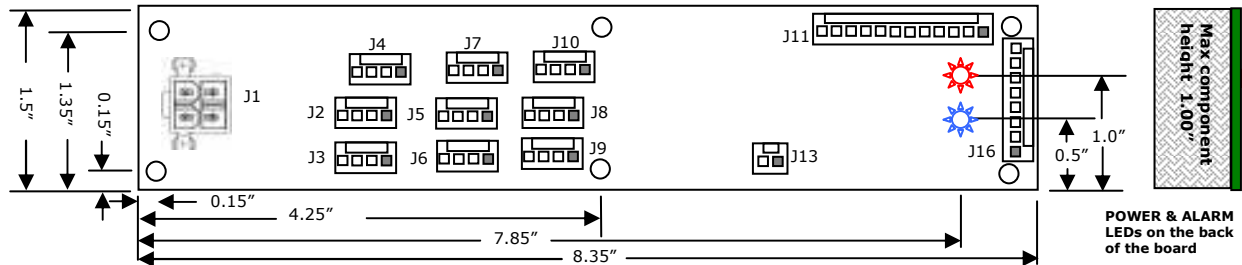

## PRONTOflow Building Blocks

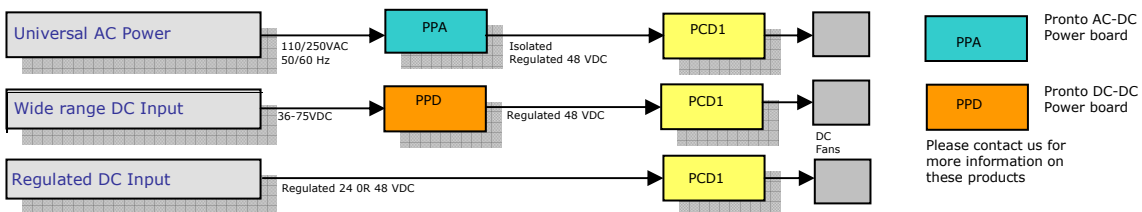

## Programmable Control

Variable	Description
T <sub>1</sub>	Low Temp: Speed = S <sub>min</sub>
T <sub>2</sub>	Mid Temp: Speed = S <sub>mean</sub>
T <sub>3</sub>	High Temp: Speed = S <sub>max</sub>
T <sub>OT</sub>	Over Temp limit
S <sub>Fail</sub>	Fan fail speed

